

High Voltage Solid-Body Fuses for Use in Vacuum, Zero G, and Shock Environment

Jeff Montgomery
AEM, Inc.

Copyright © 2000 Society of Automotive Engineers, Inc.

ABSTRACT

The high voltage power systems of satellites and spacecraft present unique fuse and fault protection challenges. High reliability fuses presently defined by MIL-PRF-23419 do not meet the increased voltage and amperage requirements for the next generation of spacecraft. Solid-body style fuses exhibit superior electrical and mechanical attributes that enable these fuses to perform reliably in the vacuum and high vibration and shock environments typically present in spacecraft applications. The construction and screening techniques for solid-body fuses described by MIL-PRF-23419/12 offer an excellent roadmap for the development of high voltage solid-body fuses.

INTRODUCTION

Historically, satellites and many other spacecraft were designed with power systems based on 28 to 50 VDC busses. For these applications, high reliability MIL-PRF-23419/8 style fuses (FM08) and MIL-PRF-23419/12 style fuses (FM12) have provided, and will continue to provide, reliable fault protection [1]. In recent years, satellite and other spacecraft operating bus voltage levels have continually risen. Many satellite power system architectures, for example, are already operating in the 100 to 135 VDC range. For these applications, only FM12 and other solid-body style fuses should be considered as FM08 style fuses have significant voltage limitations when operating in vacuum environments. A new family of solid-body fuses is required to meet the fault protection demands for the next generation of satellites and spacecraft. A vast majority of new spacecraft designs incorporate power system architectures operating at voltage levels well above the 135 VDC limitation of currently available high reliability solid-body fuses. For example, planned upgrades to the Space Shuttle include a 270 VDC power system architecture. The Space Shuttle power system fuse requirements are further defined as needing voltage ratings of 320 VDC minimum and current ratings from 100 to 1000 amperes [2]. Additionally, numerous 250

VDC fusing requirements remain unfulfilled for planned hardware on the International Space Station.

The purpose of this paper is threefold. The first objective of the paper is to present an overview of typical high reliability solid-body fuse construction and screening methods. An understanding of high reliability solid-body fuse construction and screening techniques is useful, as the same construction and screening approach is applicable to high voltage solid-body fuses presently in development. The second objective of the paper is to describe the electrical and mechanical attributes of solid-body fuses as compared with cavity style fuses. Illustrated are the advantages of solid-body fuse usage in both low and high voltage spacecraft applications. The final objective of the paper is to present an overview of the high voltage / high amperage high reliability solid-body fuses currently in development. Provided is a listing of the fuse amperage and voltage combinations that are planned. Additionally, a summary of high voltage solid-body fuse design techniques is presented.

OVERVIEW OF SOLID-BODY FUSE CONSTRUCTION AND SCREENING

CONSTRUCTION TECHNIQUES – While FM08 style fuses are constructed with a wire filament that passes through a hollow cavity (see Figure 1), solid-body fuses (FM12 styles included) are designed and constructed in a manner that ensures that the overall fuse package is substantially devoid of air. Figure 2 provides a sectional view of a typical FM12 style fuse. The fusible element is comprised of thick film gold that is deposited on a thermally and electrically insulated substrate. A complete range of fusing values is achievable by precisely controlling the fusible element print thickness and geometry. Thick film silver termination pads are placed at each end of the thick film fusible element. The fusible element is completely covered with an arc suppressive glass. Leads are attached to the silver terminations by the use of high temperature solder. The final fuse package is insert molded with an engineering thermoplastic to complete the fuse.

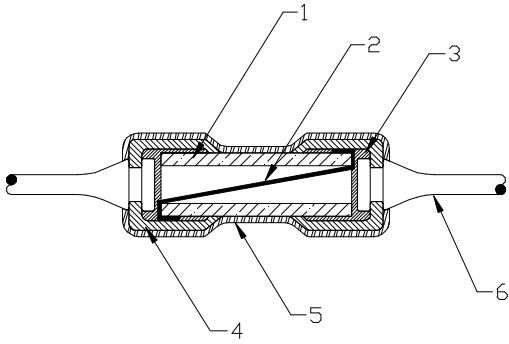

Item	Description	Material
1	Barrel	Ceramic
2	Filament Wire	Various
3	Solder	Sn 98 / Ag2
4	End Cap	9010 Brass Alloy
5	Outer Sleeve	Polyvinylidene Fluoride
6	Lead	Soft Copper With Au Plating

Figure 1. Sectional View of a Cavity Style (FM08) Fuse.

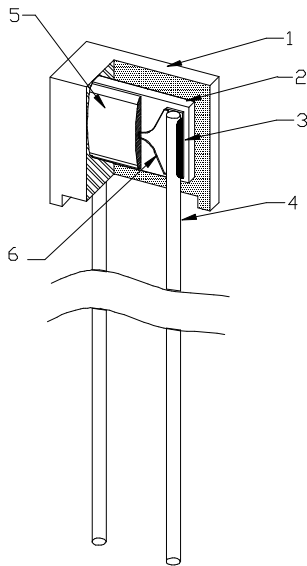

Item	Description	Material
1	Molded Case	PPS Thermoplastic
2	Substrate	96% Alumina
3	Solder	Sn96 / Ag4
4	Lead	CDA 102 Copper Au Plated With Ni Barrier
5	Arc Suppressant Coating	Lead Boro-Silicate Glass
6	Fusing Element	Thick-Film Au

Figure 2. Sectional View of a Solid-Body Style (FM12) Fuse.

Additional solid-body fuses, manufactured by AEM Inc., are constructed similarly, except that the fusible element is comprised both of thick film gold and gold wire portions. Many of the higher amperage fuses (voltage ratings above 72 VDC) are constructed with multiple fusible elements placed in an electrically parallel path on the fuse substrate assembly. For surface mount applications, the standard thick film fusible element can also be packaged in the reverse "J" package. A sectional view for this package configuration is indicated in Figure 3.

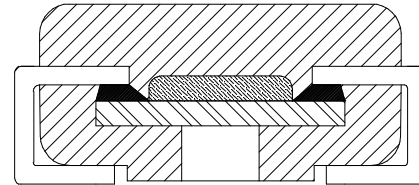

Figure 3. Sectional View of a Reverse J, Surface Mountable Fuse Package.

ELECTRICAL / MECHANICAL SCREENING - The electrical and mechanical screening for FM12 style fuses was developed specifically to ensure that these fuses are suitable for use in spacecraft environments. Accordingly, the standard Group A electrical and mechanical screening for FM12 style fuses is more comprehensive than the standard electrical and mechanical screening for other MIL-PRF-23419 fuses. Group A screening is conducted on 100% of the fuses within the manufacturing lot and consists of the following inspections and tests:

- Pre-Cap Visual Inspection
- Visual/Dimension Inspection (after molding and serialization operations)
- Initial Voltage-Drop Measurement at Rated Current
- Thermal Shock Testing (5 cycles: -65°C to +125°C)
- 168 Hour Rated Current Burn-in
- Final Voltage-Drop Measurement at Rated Current (delta-V less than 10% from initial value)
- Cold Resistance Measurement
- Overload Current Characterization (approximately 50 fuses are cleared at overloads ranging from 200% to 1000% overloads: fuses selected for testing represent the lowest/highest voltage-drops within the manufacturing lot)
- Radiographic Inspection
- Visual and Mechanical Inspection

The 168 hour burn-in, overload current characterization and radiographic inspection tests are unique to the MIL-PRF-23419/12 Fuses. Additionally, the FM12 fuse style qualification screening requirements were also specifically tailored for spacecraft requirements and include thermal vacuum and extended life testing. The solid-body design of FM12 style fuses, in conjunction with comprehensive electrical and mechanical screening, provides for fuses with the following attributes:

- Guaranteed Minimum and Maximum Clearing Times (independent of vacuum condition)
- Safe Interruption of Overload Currents at Rated Voltage
- Steady-State Current Derating Based on Case Temperature (independent of vacuum condition)
- Greater Mechanical Vibration and Shock Resistance

Understandably, the above FM12 style fuse attributes are also desired high voltage solid-body fuse attributes. As is the case, proven solid-body construction techniques as well as proven FM12 style fuse electrical and mechanical screening should be effectively applied (whenever practical) to high voltage fuse design guidelines and screening plans.

ELECTRICAL AND MECHANICAL PERFORMANCE COMPARISON

CLEARING PERFORMANCE – One method for illustrating the superior clear-time performance of solid-body fuses is through a comparison of clearing specifications. Fuse clearing times are commonly specified at overload conditions ranging from 200% to 1000% of the nominal fuse rating. For example, FM12 style fuses have guaranteed clearing times specified at 250%, 400% and 600% overloads. Other fuse types may only have maximum clearing times specified at 200% and 300% overloads. Tables 1 and 2 provide a comparison of the typical clearing specifications for both cavity style (FM08) and high reliability solid-body style (FM12) fuses. For cavity style fuses, only the maximum clearing limits are specified. In contrast, both minimum and maximum clearing limits are specified for high reliability solid-body style fuses. Figure 4 provides a typical clearing curve for a FM12 style fuse, indicating both the minimum and the maximum clearing limits. It should also be noted that the published clearing specifications for the cavity style fuses are valid for operation in non-vacuum environments only. High reliability solid-body fuses will meet published minimum and maximum clearing specifications in both non-vacuum and vacuum environments. Likewise, the developmental high voltage solid-body fuses will also have minimum and maximum clearing times specified.

Table 1. Specified Clearing Characteristics for a Cavity Style (FM08A 125V 5.0A) Fuse.

Overload Current Level (Percent)	Minimum Specified Clearing Time (Seconds)	Maximum Specified Clearing Time (Seconds)
200%	0	1.0
300%	0	0.1

Table 2. Specified Clearing Characteristics for a Solid-Body Style (FM12A 125V 5.0A) Fuse.

Overload Current Level (Percent)	Minimum Specified Clearing Time (Seconds)	Maximum Specified Clearing Time (Seconds)
250%	0.005	0.300
400%	0.0005	0.015
600%	0.000075	0.003

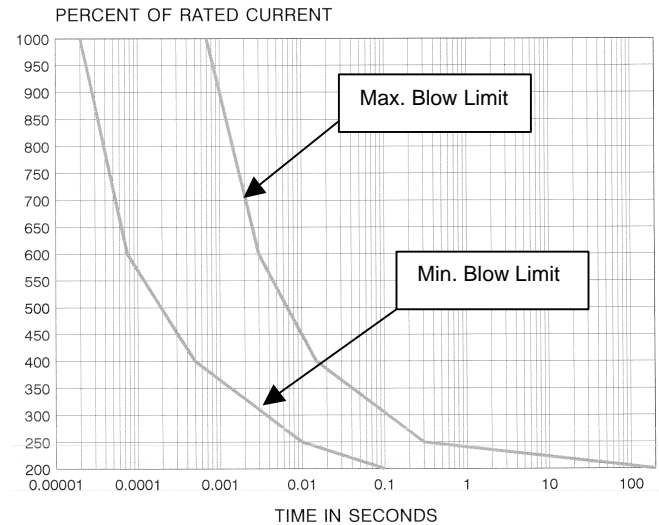

Figure 4. Typical Clearing Limits for Solid-Body FM12 Style Fuse.

The importance of minimum specified clearing times can not be overemphasized, especially for fuses utilized in satellite and spacecraft applications. Without guaranteed minimum clearing times, a circuit designer cannot adequately ensure that fuse degradation or fuse failure (nuisance blow) will not occur following a transient current inrush event.

The short circuit interrupt rating (the maximum current level that a fuse can safely interrupt) for solid-body fuses is generally greater than that specified for equivalent (same voltage and current rating) cavity style fuses. For instance, the FM08 style fuses have a short circuit interrupt rating of 300 amps maximum while the FM12 style fuses are rated to 1000 amps maximum. The need for increased short circuit interrupt rating for fuses is rapidly becoming a critical issue, especially for high

voltage spacecraft applications. As a result of this need, the short circuit interrupt requirement for high voltage solid-body fuses is 10,000 amps.

CLEAR-TIME PERFORMANCE IN SOFT VACUUM ENVIRONMENTS – In 1999, Goddard Space Flight Center (GSFC) conducted a series of vacuum / overload current tests on FM08 and other cavity style fuses to determine threshold voltage limits for safe overload current interruption. As a result of these tests, GSFC concluded that in a soft vacuum environment (1.0 to 1.5 torr) and at voltage levels above 50 VDC, the FM08 and FM04 style fuses would not reliably interrupt an overload current. Under these circumstances, continued fuse arcing (following the fuse clearing initiation process) could result in damage to the fuse package and surrounding components and not protect the power system as intended. The results of GSFC’s findings were published in late 1999 [3]. Although FM12 style fuses are routinely tested at vacuum pressures less than 5×10^{-5} torr, no published test results were available for overload current testing in a soft vacuum environment. As a result of the needed evaluation, AEM conducted a series of soft vacuum tests on FM12 style and other AEM solid-body style fuses.

Overload Current Testing of Solid-Body Fuses in a Soft Vacuum - The overall test plan followed by AEM was similar to the procedure developed by GSFC during the FM08/FM04 style fuse vacuum / overload current tests. GSFC prepared the FM08/FM04 style fuses for vacuum testing by drilling a small hole in the ceramic barrel to allow for the interior fuse cavity to equilibrate quickly to the pressure within the test chamber. As this step is not applicable to the solid-body fuses (no significant internal air cavity), AEM Inc. proceeded with the vacuum/overload current testing without drilling or cutting holes in the external fuse case.

The solid-body style fuse types obtained for testing included:

- AEM Inc. Standard P600L Model (commercial equivalent of FM12 style fuses)
- AEM Inc. Non-standard P600L Model with higher than standard amperage/voltage ratings (125 VDC and 135 VDC samples evaluated)
- AEM Inc. P800L Model (slow blow solid-body fuses – rated at 72 VDC nominally)

A complete listing of the fuse models evaluated is indicated in Table 3. The AEM Part Numbers and the associated MIL-PRF-23419/12 Part Numbers (if applicable) are noted. The fuses selected for testing represented the low, mid and high amperage fuse styles presently available from AEM Inc. for each model evaluated.

Table 3. Solid-Body Fuses Subjected to Soft Vacuum / Overload Current Testing.

AEM Part Number	MIL-PRF-23419/12 Part Number
P600L-125-1/8	FM12A125V1/8A
P600L-125-1.0	FM12A125V1.0A
P600L-125-5.0	FM12A125V5.0A
P600L-135-1/8	No MIL-PRF-23419 Equivalent
P600L-135-1.0	No MIL-PRF-23419 Equivalent
P600L-135-5.0	No MIL-PRF-23419 Equivalent
P600L-125-10.0	No MIL-PRF-23419 Equivalent
P600L-125-15.0	No MIL-PRF-23419 Equivalent
P600L-135-10.0	No MIL-PRF-23419 Equivalent
P600L-135-15.0	No MIL-PRF-23419 Equivalent
P600L-72-7.5	FM12A72V7.5A
P600L-72-15.0	FM12A72V15.0A
P800L-72-2.0	No MIL-PRF-23419 Equivalent
P800L-72-15.0	No MIL-PRF-23419 Equivalent

Test Method - The test set-up utilized for evaluation consisted of overload current generation equipment and a vacuum chamber. An electrical schematic of the test station is indicated in Figure 5.

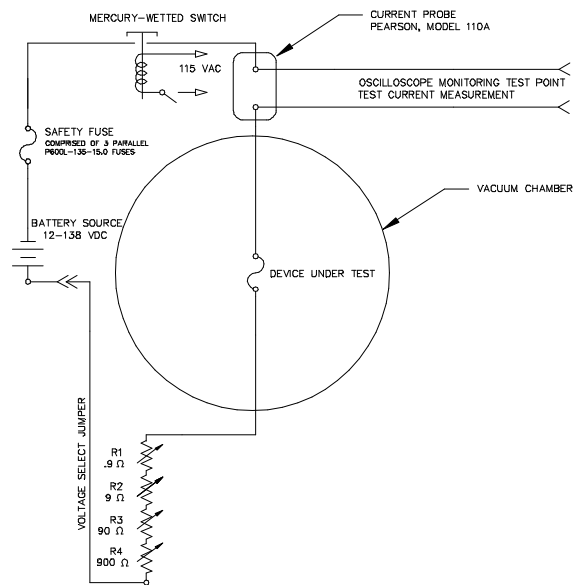

Figure 5. Schematic Diagram of Overload Current / Vacuum Test Set-Up.

The voltage source was comprised of a series of 12 VDC marine style batteries. The supply voltage was adjusted to provide an open circuit potential slightly exceeding the maximum voltage rating of the fuse. The current output was adjusted to generate an overload current in excess of 100 amps (simulate a hard short circuit). A series protection fuse (typically 2-3 times the nominal rating of the fuse under test) was placed in the test circuit to open (blow) if the fuse under test exhibited a sustained arc. It should be noted that the resistance of some of the lower amperage fuses limited the maximum output current to levels significantly less than 100 amps. For instance, a typical P600L-125-1/8 fuse exhibits a cold resistance of 8.0 Ω. As a result, the maximum test

current achievable is on the order of 15.6 amps (actual test current was less for 1/8 amp fuses tested due to circuit rise time). The approximate test circuit inductance was 23 uH. The vacuum chamber containing the fuse under test was pumped down to a pressure from 1.0 to 1.5 torr. The fuse was then subjected to the overload current. A digital oscilloscope was used to monitor the current through the fuse during the clearing event and provide a means for recording and plotting the overload clearing waveform. The clearing waveforms were then used to classify each tested sample as “sustained arc” or “no sustained arc”. To validate the test set-up, several FM08 style fuses were subjected to overload current testing at 115 VDC. When five FM08A 125V 10A fuses were tested, four were found to exhibit sustained arcing. A sample clearing waveform for one of the FM08 style fuses that exhibited sustained arcing is noted in Figure 6. The sustained arcing was interrupted only after the series safety fuse opened. The waveform in Figure 7 is typical of the clearing action exhibited by the solid-body fuses tested (P600L-125-15.0). Ten solid-body fuse specimens for each model type were subjected to testing.

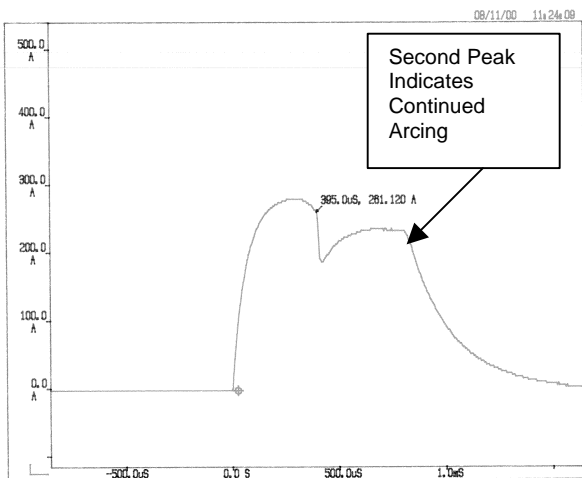

Figure 6. FM08 Style Fuse Clearing Waveform.

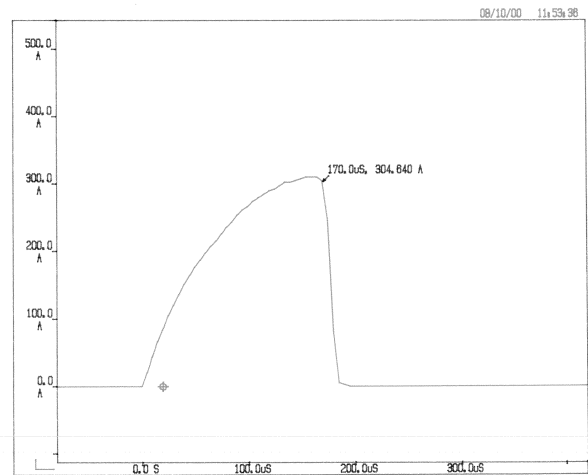

Figure 7. Typical P600L-125-15.0 Fuse Clearing Waveform.

TEST RESULTS / DISCUSSION - Table 4 indicates the test voltage and typical peak current attained during overload current / vacuum testing.

Table 4. Test Voltage and Typical Test Current Levels for Fuses Tested in Soft Vacuum.

AEM Part Number	Test Voltage (VDC)	Peak Current (Amps)	No Sustained Arc
P600L-125-1/8	128	3.8	Pass
P600L-125-1.0	128	34	Pass
P600L-125-5.0	128	95	Pass
P600L-135-1/8	137	4.0	Pass
P600L-135-1.0	137	36	Pass
P600L-135-5.0	137	96	Pass
P600L-125-10.0	128	248	Pass
P600L-125-15.0	128	305	Pass
P600L-135-10.0	137	264	Pass
P600L-135-15.0	137	310	Pass
P600L-72-7.5	77	138	Pass
P600L-72-15.0	77	205	Pass
P800L-72-2.0	77	89	Pass
P800L-72-15.0	77	212	Pass

In all, 140 solid-body style fuses were subjected to overload current testing in a soft vacuum environment. None of the fuses exhibited a sustained arc. A comparison of clearing waveforms for the same style fuses cleared at one atmosphere (760 torr) revealed no significant differences. Future overload current / soft vacuum tests are planned for un-encapsulated (un-molded) solid-body style fuses (FM12) using an alternative means for supporting the arc suppressant. Additionally, overload current / soft vacuum testing of high voltage solid-body fuses is also advisable, as continued arcing is more probable when voltage levels are increased.

STEADY-STATE CURRENT DERATING - For vacuum operation, the steady-state current derating guidelines for cavity style fuses (FM08) are specified in MIL-STD-975 [4] (superseded by PPL-21) [5]. MIL-STD-975 requires significant steady-state current derating for FM08 style fuses as a result of the possible loss of internal air pressure during extended vacuum operation. Table 5 specifies the derating for FM08 style fuses with ratings of 1/8 to 15 amperes.

Table 5.
MIL-STD-975 / PPL-21 Steady-State Current Derating Guidelines for Air Cavity Style (FM08) Fuses.

FM08 Fuse Rating (Amperes)	Derate to the Following (%) of Rated Current
2.0 through 15	50%
1.0 to 1.5	45%
0.750	40%
0.500	40%
0.375	35%
0.250	30%
0.125	25%

The severe derating of the lower amperage FM08 styles results from its low-mass fusible element that is more affected by a reduction in convection cooling following the loss of cavity air pressure. In addition to vacuum derating, MIL-STD-975 also specifies additional derating of 0.5 percent/°C for an increase in ambient temperature above 25°C. Failure to properly derate cavity style fuses for vacuum operation may result in a blown fuse. In contrast, the steady-state current derating guidelines of solid-body style fuses (FM12) are dependent upon case temperature and are independent of vacuum condition. Figure 8 indicates the current derating curve as specified by MIL-PRF-23419/12.

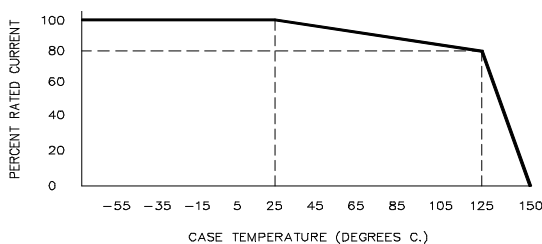

Figure 8. MIL-PRF-23419/12 (FM12 Style) Solid-Body Fuse Current Derating Guidelines.

Since FM12 style fuses are constructed with a solid-body, they do not experience a loss of pressure during extended vacuum operation and are therefore not subject to the severe derating criteria of MIL-STD-975. As the high voltage solid-body fuses will also be fabricated with a solid-body technique, the preferred derating guidelines of Figure 8 will be applicable.

VIBRATION AND SHOCK - Table 6 provides a comparison of the typical shock and vibration ratings of cavity style (FM08) and solid-body style (FM12) fuses.

Table 6.
Specified Vibration and Shock Test Levels for FM08 and FM12 fuses.

Part Type	Specified Vibration Level	Specified Shock Level
FM08 (Air Cavity)	10 G's Peak to 2000 Hz. (MIL-STD-202, Method 204, Test Condition C)	100 G's Peak for 6 mS (MIL-STD-202, Method 213, Test Condition I)
FM12 (Solid-Body)	30 G's Peak to 3000 Hz. (MIL-STD-202, Method 204, MIL-PRF-23419/12)	1500 G's Peak for 0.5 mS (MIL-STD-202, Method 213, Test Condition F)

As expected, solid-body fuses can withstand higher levels of shock and vibration. A major concern with cavity/wire-filament fuses relates to the possibility of long-term fatigue-fractures that may occur when vibration levels approach the fundamental resonant frequency of the wire filament. There are several documented instances for this type of failure. One example of fatigue-fracture failure was documented in Gidep Alert F1-A-82-04 [6]. Another example of vibration induced fatigue-fracture was presented by GSFC following an investigation of fractured gold bonding wires in a solid state recorder [7].

As solid-body fuses are designed and constructed with fusible elements that are completely surrounded by an arc suppressing media (no movement permitted), they are less likely to experience a vibration induced failure. Given the relatively high levels of shock and vibration that are often associated with spacecraft launch, the increased mechanical ratings afforded by solid-body fuses are very desirable.

SOLDERING HEAT RESISTANCE – Due to their lower overall internal mass, cavity style fuses may also be more susceptible to soldering heat damage during installation. Gidep Alerts F3-A-98-05 [8], LX-A-88-03A [9] and a NASA application note [10] have documented the heat sensitive nature for two types of cavity style fuses. Solid-body fuses, on the other hand, have greater element/arc suppression mass, and are less likely to sustain damage during soldering operations.

REDUNDANT FUSING – In an attempt to mitigate the previously discussed electrical and mechanical limitations, cavity style fuses have often been utilized redundantly. In redundant fusing applications, two cavity style fuses are installed in an electrically parallel circuit (one fuse in series with a power resistor). In this configuration, catastrophic circuit failure is avoided should one fuse suffer a mechanical failure. One problem with the redundant fusing approach described is the need for three components rather than one fuse. The extra components add undesired circuit weight (primarily due to the power resistor) and also result in a need for additional assembly and testing effort. While high

reliability solid-body style fuses generally are more costly (in terms of purchase price) than high reliability cavity style fuses, redundant fusing techniques are not required. As a result, assembly and testing costs associated with solid-body fuses are less.

HIGH VOLTAGE / HIGH AMPERAGE FUSE DEVELOPMENT

HIGH VOLTAGE FUSE FAMILIES – Three high voltage solid-body fuse families are currently in development and will be qualified during the next two years. These include:

- 250 VDC rated fuses with an amperage range from 1.0 to 15 amps
- 400 VDC rated fuses with an amperage range from 1.0 to 100amps
- 660 VDC rated fuses with an amperage range from 1.0 to 100 amps

For each of the high voltage solid-body fuse families noted above, increased amperage capability may be realized through the operation of electrically paralleled fuses. For example, a specific requirement for 250 VDC, 20 amp fusing is satisfied by the use of two electrically matched 250 VDC, 10 amp devices, electrically mounted for parallel operation. Likewise, a 400 VDC, 500 amp fusing requirement would be satisfied by the installation of five electrically matched 400 VDC, 100 amp fuses. Short circuit interrupt ratings, for the 400 VDC and 660 VDC fuses, will be 10,000 amps.

CONSTRUCTION TECHNIQUES - The new high voltage solid-body fuses will be fabricated with a solid-body technique similar to that utilized for FM12 style fuses. The fusible elements will be comprised primarily of Au and Ag based alloys and may (depending on the clearing and voltage requirement) also include either thick film, foil or wire portions. Key compositional changes to the ceramic/glass arc suppressive materials utilized will be necessary to achieve the desired higher voltage ratings. As would be expected, significant package modifications, including increased length, width and larger lead terminations are required to meet the increased current-carrying capability and increased voltage requirements. As these fuses are intended for use in satellite and spacecraft applications, the raw materials utilized for construction will be screened and qualified to the NASA outgassing requirement specified by ASTM E595 [11].

SCREENING - The planned electrical and mechanical screening of the new solid-body high voltage fuses is based upon the standard FM12 style fuse screening. Group A screening will continue to include overload current characterization testing to ensure that minimum and maximum clearing times are maintained. Accordingly, the qualification test routine will also be identical and will include thermal vacuum testing as defined by MIL-PRF-23419/12. Additional overload current testing in a soft vacuum is also recommended.

To electrically evaluate high voltage fuses, new overload current test equipment was designed and fabricated. Figure 9 provides an electrical schematic for an overload current clearing tester capable of evaluating high voltage fuses with voltage ratings up to 660 VDC and amperage ratings up to 100 amps.

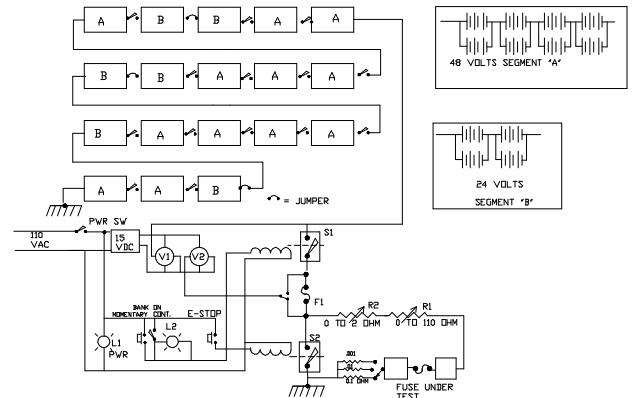

Figure 9. Electrical Schematic for High Voltage Overload Current Tester.

The overload current tester is used to evaluate and characterize fuse performance at overload current levels ranging from 200% to 1000% (2X to 10X) of the nominal fuse rating. Typically, 70 to 100 fuses (from each manufacturing fuse lot) are subjected to overload current testing to ensure that minimum and maximum clearing times are maintained. Figure 10 provides an electrical schematic for a short circuit overload current tester.

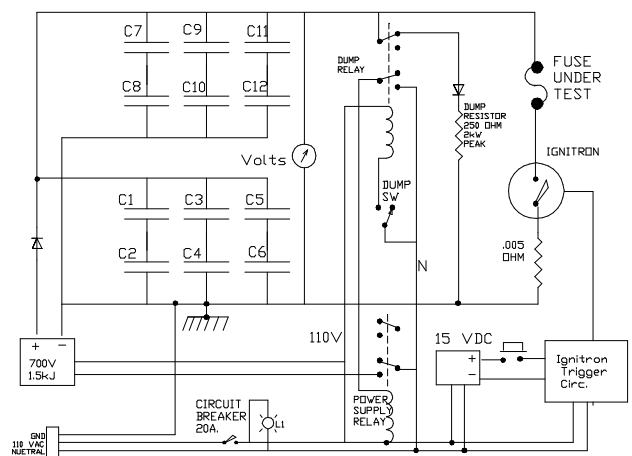

Figure 10. Electrical Schematic for Short Circuit Overload Current Tester.

The short circuit interrupt tester described, is capable of delivering overload currents up to 20,000 amps at open circuit voltage levels up to 700 VDC.

CONCLUSION

In concluding, this paper has provided an overview of the fabrication and screening techniques utilized for high reliability solid-body style fuses. The paper has suggested that proven fabrication and screening techniques for solid-body FM12 style fuses should also be applied to the next generation of high voltage solid-body fuses now in development. A comparison of electrical and mechanical characteristics of cavity style fuses with solid-body style fuses identified several key solid-body fuse attributes that make these fuses the preferred choice for both low and high voltage spacecraft applications. The paper presented the main performance advantages of solid-body fuses. These performance advantages included:

- Consistent minimum and maximum clearing times regardless of vacuum condition
- Ability to clear in soft vacuum environments without exhibiting excessive arcing
- Steady state current derating is dependent only on fuse case temperature and is independent of vacuum condition
- Greater short circuit interrupt ratings
- Improved mechanical shock and vibration survivability
- Redundant fusing is not required

Finally, the paper provided a description of the high voltage solid-body fuse families currently under development and provided an overview of the construction technology utilized.

REFERENCES

1. MIL-PRF-23419, Military standard for fuses. See also slash sheet MIL-PRF-23419/12 and MIL-PRF-23419/8.
2. S. Atreya, Boeing Presentation "Electrical APU 270 VDC Power Distribution and Control Working Group Session at Glenn Research Center", dated July 18, 2000.
3. H. Leidecker, J. Slonaker, "Evacuated FM08 Fuses Carry a Sustained Arc in a Bus over 75 VDC," 25TH International Symposium for Testing and Failure Analysis, pp. 225–229, November 14-18, 1999.
4. MIL-STD-975, Military standard for NASA Standard Electrical, Electronic and Electromechanical Parts.
5. PPL-21, Goddard Space Flight Center Preferred Parts List.
6. Gidep Alert F1-A-82-04, "Fuses and Protective Devices," February 16, 1983.
7. H. Leidecker, S. Hull, "Vibration-induced Fatigue Failures in Bonding Wires Used in Stacked Chip Modules".
8. Gidep Alert F3-A-98-05, "Fuses, Cartridge, Instrument Type, Style FM08," June 19, 1998.
9. Gidep Alert LX-A-88-03A, "Circuit Protection, Fuse, Instrument Type, Style FM04," March 1988.
10. <http://nepp.nasa.gov/npsl/Fuses/23419/23419aps.htm>.
11. ASTM E595, Standard Test Method for Total Mass Loss and Collected Volatile Condensable Materials from Outgassing in a Vacuum Environment.